

## T4360/T6360 LINE VOLTAGE ROOM THERMOSTATS

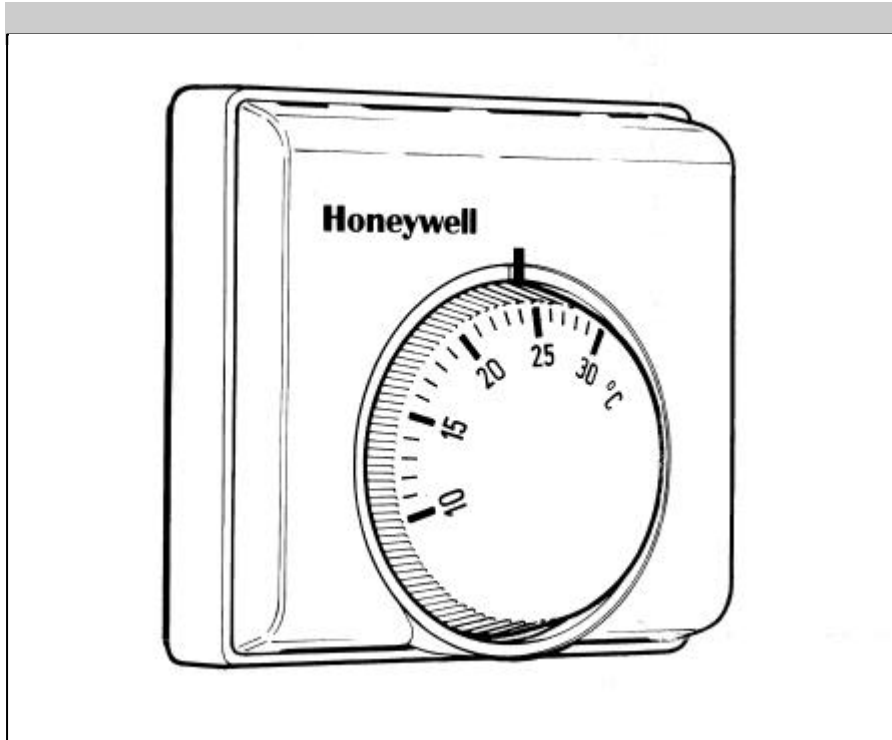

### PRODUCT SPECIFICATION SHEET

The T4360/T6360 range of thermostats are designed to provide automatic ON/OFF control for gas valves, circulation pumps, relays and zone valves in all heating, cooling, or heating/cooling installations where single or changeover switching up to 10 A (resistive load) or 3 A (inductive load) is required.

In addition a 16 A (resistive load) variant is available for direct switching of high current carrying loads.

Nine models of the thermostat are available, in a wide range of feature combinations.

### FEATURES

- Dual diaphragm sensing element ensures close temperature control for all loads and applications
- Attractive modern styling makes this thermostat ideal for locating in the living space
- Available with or without heat anticipation to suit the application
- The T6360 has changeover contacts for use in cooling or heating/cooling applications
- Versions with switches for positive-off selection, or summer/ winter (heat/cool) changeover operation
- Mounts directly onto wall or conduit box
- Improved easy-to-wire terminals with built-in conductor clamps to ensure wiring is retained securely
- Double insulated. No earth wire required for operation. Earth "parking" terminal available on selected models
- Optional extras available are:
  - range stops F42006646-001
  - tamperproof cover F42007110-001 (opaque) or F42007110-002 (transparent)
  - additional wallplate for special mounting requirements F42007789-001

# SPECIFICATIONS

MODEL	HEAT ANTICIPATOR	CHANGEVER CONTACTS	INDICATOR LAMP	SUMMER/WINTER SWITCH	ON/OFF SWITCH	16 AMP RATING	FROST PROTECT FUNCTION	TAMPER-PROOF COVER	NIGHT SETBACK HEATER	SPECIAL ANTICIPATOR
T4360A							●	●		
T4360B			*			●				
T4360C	*		*		●				*	
T4360D			*	●				*		
T4360E	●								●	
T4360F										○
T6360A		●	*							
T6360B	●	●	*					*		
T6360C		●	*							

\* Versions available with or without this feature  
 ○ For thermal actuator control

Switch type : T4360 S.P.S.T. (Heating)  
 T6360 S.P.D.T. (Heating/Cooling)

Electrical rating : T6360A,B,C 10(3) A Terminal 3 (Heating), Terminal 4 (Cooling)  
 T4360A,C,E 10(3) A Terminal 3 (Heating)  
 T4360B 16 A Terminal 3 (Heating)  
 T4360D 6(2) A Terminal 2 (Heating or Cooling)  
 T4360F 2(2) A Terminal 3 (Heating)  
 Manual switches on T4360C,D and T6360C rated 10(3) A

Temperature setting range : 10 to 30°C  
 (0 to 20°C - T4360A only)

Terminals : Terminals sized to accept up to 2 x single or multi-stranded wires from 1.0 mm<sup>2</sup> to 2.5 mm<sup>2</sup>.  
 16 A version will accept one 4.0 mm<sup>2</sup> wire per terminal.  
 Lamp terminals suitable for only one wire per terminal up to 2.5 mm<sup>2</sup> max

Each terminal has a conductor clamp for securing the wiring conductor and is suitable for both blade and cross-head screwdrivers.  
 Earth "parking" terminal to comply with IEC guidelines.

Performance : Maximum differential 1.0°C at 20°C at heat ramps of 3°C per hour, with anticipator connected.  
 Typical differential 0.5°C.

Switch life : Greater than 100,000 operations (all loads) for main switch.  
 10,000 operations for auxiliary on/off or heat/cool switches.

Environmental requirements : Operating temperature range 0 to 40°C  
 Shipping and storage range -20 to 50°C  
 Humidity range 0 to 90% R.H. (non-condensing)

Approvals : CE mark, complying with standards EN60730-1 (1995), EN55014-1 (1997), EN55014-2 (1996).  
 Product must be wired as shown for CF compliance.

# DIMENSIONS

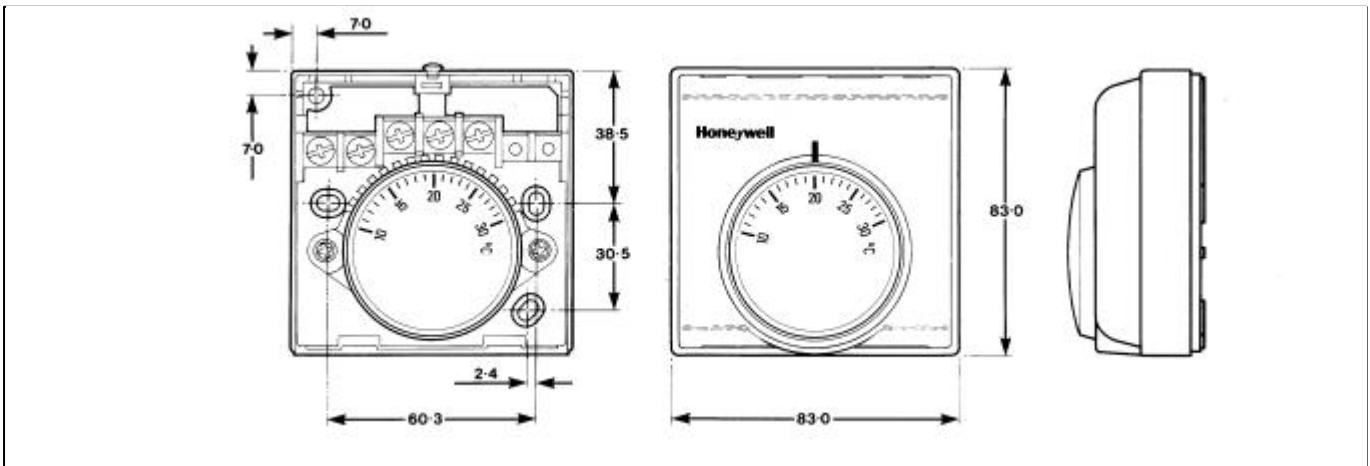

## INSTALLATION

### IMPORTANT

1. The installer must be a trained service engineer
2. Disconnect the power supply before beginning installation

### Location

A T4360/T6360 room thermostat is the temperature control element in your heating system and must be located in a position with good air circulation at average temperature - on an inside wall about 1.5 m above the floor.

Do not position the thermostat in draughts, near hot or cold air from water pipes or radiant heat from the sun or appliances.

### Mounting the thermostat

The T4360/T6360 can be mounted directly on the wall or on a conduit box (see Fig. 2). Mounting screws are provided for both alternatives.

An additional wall-plate is available for special mounting requirements.

### Wiring the thermostat

The standard wiring access is via a hole in the base of the thermostat, near the top edge. There are also 4 breakouts on the cover (2 on top and 2 on the sides) for surface wiring requirements.

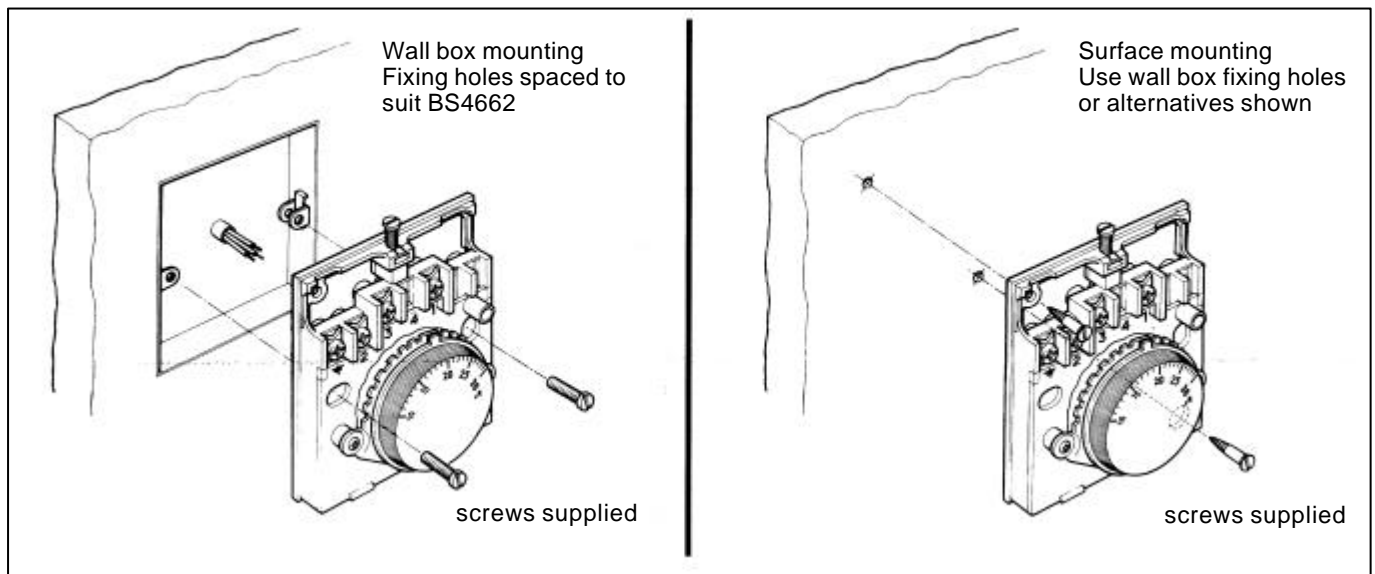

Fig.2 Mounting the Thermostat

## OPERATION

### Sensing Element

The thermostat sensing element comprises two circular, flexible metal plates welded together at the rims encapsulating a liquid whose pressure changes greatly in response to small variations in temperature. In effect, this dual diaphragm forms a 'bellows' which expands/contracts in sympathy with the ambient temperature changes - this movement serving to operate a snap acting switch rated to control the heating or cooling circuit.

### Heat Anticipator

It is recommended that a thermostat with heat anticipator is used for systems with a high heating ramp rate. This will overcome the overshoot and undershoot problems often found in this type of installation.

### Indicator Lamp

A 'potential-free' indicator lamp is available on some models. This can be wired as required to indicate when power has been switched to the (heating or cooling) load (see Wiring).

To wire the lamp as 'boiler lockout' indicator, follow boiler manufacturers wiring instructions.

### Auxiliary Switches

The on/off switch provides a means of manually isolating the mains input to the thermostat, to provide a positive off feature.

The summer/winter switch provides the user with a means of manually switching between a heating output (activated on temperature fall) to a cooling output (activated on temperature rise).

### Frost Protect Thermostat

The frost protect thermostat prevents water pipes from freezing in exposed locations. It should be positioned close to where the pipework is most exposed to external chilling and connected to override all existing time and temperature controls. The frost protect thermostat is provided with an indicator mark at the 5°C point, and is supplied with a tamperproof cover.

WIRING

